

ELO Double stainless steel coat hook, brushed finish

Reference: **AM-18-S**

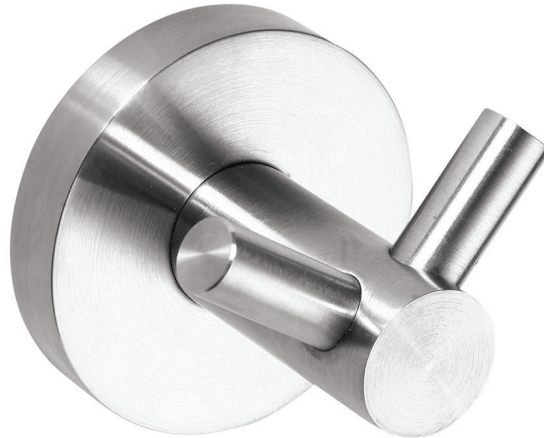

Description

ELO double wall-mounted hook in brushed stainless steel finish, offering robustness and durability.

Easy to install.

Aesthetic and functional design with a stable base, allows easy hanging of clothes or other items in public sanitary spaces.

Features

Double stainless steel hook, brushed finish.

Invisible wall mounting (screws and plugs provided).

Locking by Allen screw concealed under the hook.

Weight: 0.169 kg

Dimensions: Ø55 x D50 mm

10-year warranty.

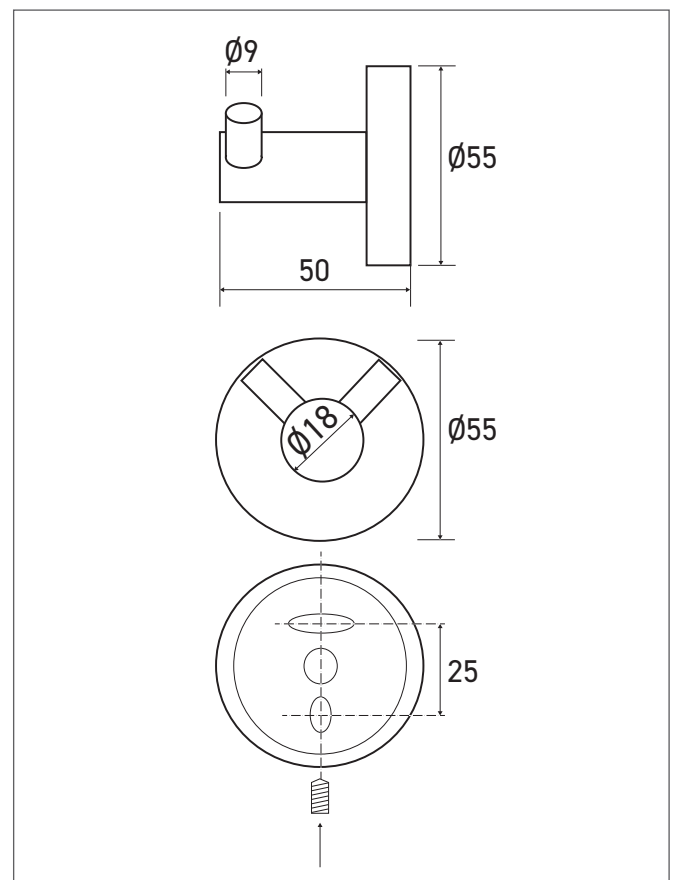

Reference

ELO double wall-mounted stainless steel hook

- **AM-18-S** brushed finish