

**Vandal-proof stainless steel standing drinking fountain**

Reference: **FB-010**



**Description**

Stainless steel freestanding drinking fountain designed to resist vandalism and for safe use in sensitive locations such as psychiatric hospitals, penitentiary centers...

Vandal-proof stainless steel mouth rinse spout with anti-hanging anti-rotation fixation, with recessed push button.

Bottle filling niche with second recessed push button.

Side access panel for floor and wall fixings and plumbing connexion (filter access if added).

**Features**

AISI 304 stainless steel quality thickness 1.5 mm, brushed finish.

Water inlet F1/2" (x2). Drain 1 1/4" (x2).

Perforated grid drains with free flow.

Floor and wall mounting.

Weight 30 kg.

Dim.: 400 x 400 x H950 mm.

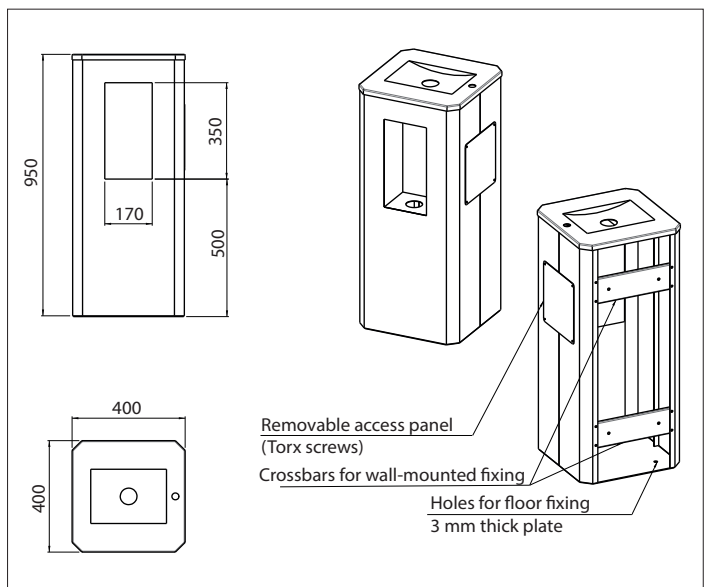

**Reference**

Vandal-proof stainless steel drinking fountain on pedestal

- **FB-010**