

Stainless steel semi-pedestal drinking fountain with touch-free faucet

References: **FP-002ET / FP-002EP**

Description

Stainless steel semi-column pedestal drinking fountain with touch-free automatic activation mouthwash faucet.

Ease of use and improved hygiene, reducing the risk of cross-contamination.

Backsplash to protect the wall from water and facilitate cleaning.

Enclosed underside for concealed drainage and additional protection against vandalism or dirt accumulation.

Designed for indoor use in high-traffic locations such as schools, offices, railway stations, airports, department stores, communal catering facilities, hospitals, sports halls, etc.

Features

AISI 304 stainless steel drinking fountain, 1 mm thickness, brushed and polished finish.

Stainless steel faucet with infrared sensor, powered by 230/24V transformer or 6V batteries.

Adjustable flow rate (min. 0.4 L/min.).

STANDARD operating mode = water flows as long as the person or object is within the detection area

or ON/OFF operating mode = water flows when the hand is brought to within 5-10 cm of the sensor and stops after a set duration, or sooner, by bringing the hand close again.

Solenoid valve, flexible hoses, angled stop valve with filter integrated.

Low battery indicator light for replacement.

Security stop after 5 minutes of uninterrupted use (adjustable).

Periodic hygiene rinse.

Optional gooseneck time-flow tap for filling carafes or bottles.

Pressed basin \varnothing 280 x H40 mm.

Vandal-proof perforated drain. Backsplash H30 mm.

Floor installation with wall fixing.

3 adjustable feet for levelling. Fixings supplied.

Water inlet M 3/8".

Waste outlet pipe \varnothing 19 mm.

Dim.: W350 x D360 x H910 mm.

CE. Electronics guaranteed 5 years.

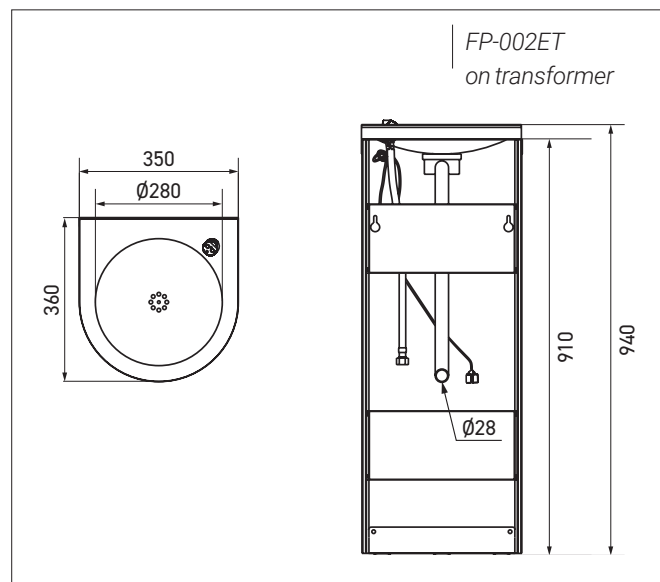

References model choices

Touch-free stainless steel drinking fountain semi-column

- **FP-002ET** **mains-powered**
- **FP-002EP** **battery-powered**

Options

- SLD03 remote control for setting adjustment (detection range, flow duration, on/off, periodic flush)
- With second automatic touch-free gooseneck spout
- AISI 316 stainless steel quality for coastal installations (on request, minimum quantity)