

Wall-mounted stainless steel touch-free hygiene handwash basin

Reference: **LVM-122-T / LVM-122-P**



Description

Touch-free stainless steel handwash basin, for professional kitchens and food retail, with integrated electronic activation (for cold or pre-mixed water).

Rotating gooseneck spout.

One-piece rectangular sink with high backsplash.

Complies with HACCP requirements.

Features

AISI 304 stainless steel quality, brushed finish, thickness 1.2 mm.

Infrared presence detection.

Powered by 9V battery or 230/9V transformer.

Low battery indicator light for replacement.

Security stop after 90 seconds of uninterrupted use.

Periodic hygiene rinse.

Water inlet connection on M1/2" solenoid valve with filter.

Hot/cold water pre-mixer with check valves.

Standard 1 1/4" drainage.

Pressure: 0.5-8 bar. Maximum temperature 70°C.

Trap included.

Wall-mounted. Fixings supplied.

Dim. W400 x D330 x H200 mm + backsplash H320mm.

Basin W320 x D250 x H128 mm.

3-year warranty. CE.

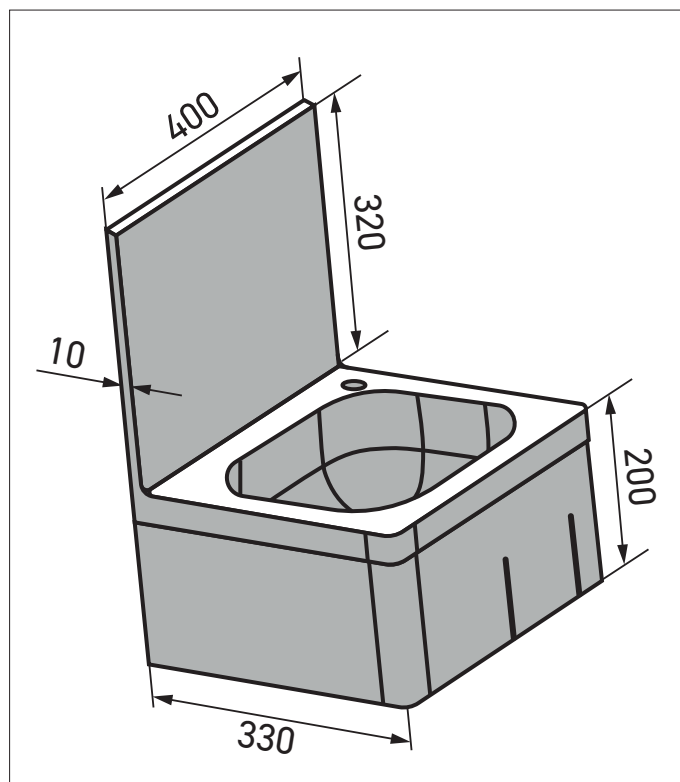

References model choices

Wall-mounted touch-free stainless steel hygiene washbasin

- **LVM-122-T** on mains
- **LVM-122-P** battery powered

Options

- RES-31 Detection settings remote control
- RED-G5 Thermostatic pre-mixer
- LVM-PB Integrated 15L stainless steel bin
- LVM-BRO Nail brush with chain
- JAC-84 400 ml ABS soap dispenser