

White 60L under counter bin for waste chute

Reference: **MKW-110-B**

Description

White bin with concealed casters for installation under a worktop or sink, to be combined with a counter-mounted waste chute.

Features

AISI 304 stainless steel, white finish.

Capacity: 60L

4 swivel caster wheels concealed from the user.

Wall support and fixings supplied.

Dimensions: W340 x D340 x H590 mm

10 year warranty.

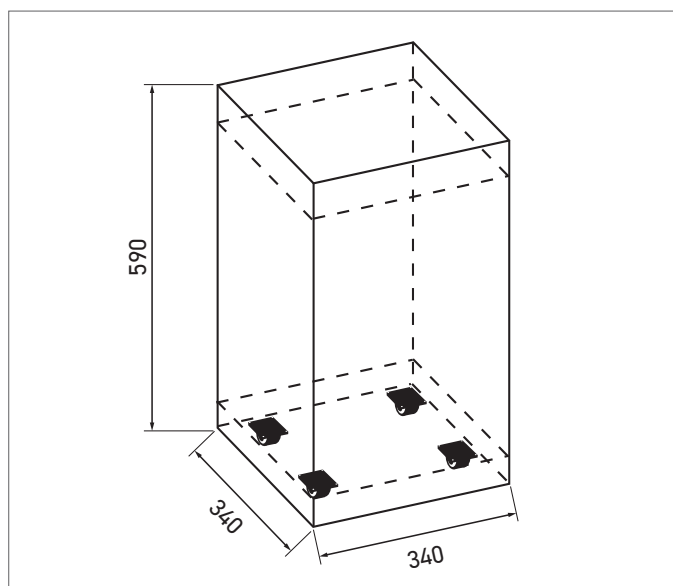

Reference

Under counter white bin

- **MKW-110-B**

Option

- Counter-mounted recessed circular stainless steel waste chute ref. MGW-501
- Finishes: matte black, stainless steel, colour