

SUPREME electronic mixer

References: [RES-150](#) / [RES-152](#) / [RES-157](#)

Description

Electronic washbasin faucet with infrared sensor.
 Particularly robust for sites prone to vandalism.
 Its elegant design adds a contemporary and polished touch to sanitary spaces.
 Designed for easy installation and maintenance, with every component seamlessly integrated into the faucet body.
 Electronic faucets reduce water consumption, save energy and optimize sanitary hygiene.

Features

- Infrared sensor with optimized presets or adjustable with remote control (flow duration, detection range, temporary stop...).
- Powered by an integrated or external 9V battery under the sink, or external 230/9V transformer.
- Low battery indicator light for replacement.
- Security stop after 90 seconds of uninterrupted use.
- Periodic hygiene rinse.
- Solid chrome-plated brass body.
- Integrated solenoid valve.
- Flow limited to 6 LPM (1.3, 1.9 or 3 LPM on demand).
- Cold and hot water supply.
- SPEX hoses (resistant to chlorinated disinfection and temperature increases) with integrated check valves.
- Filters supplied.
- Water pressure: 0.3 – 8.0 bars / Maximum temperature 70°C.
- CE. ACS. 3-year warranty.

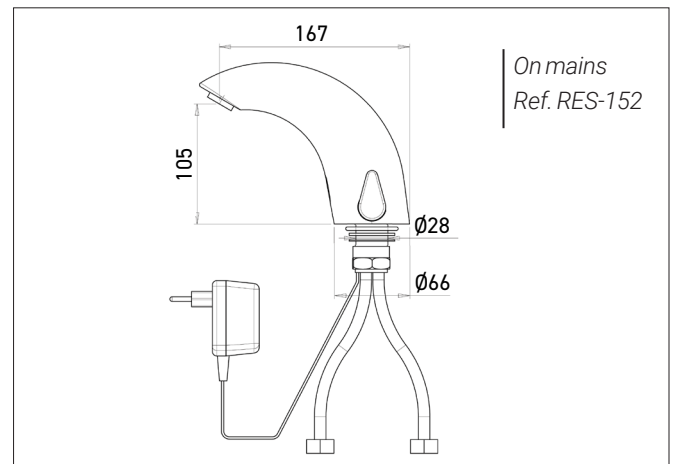
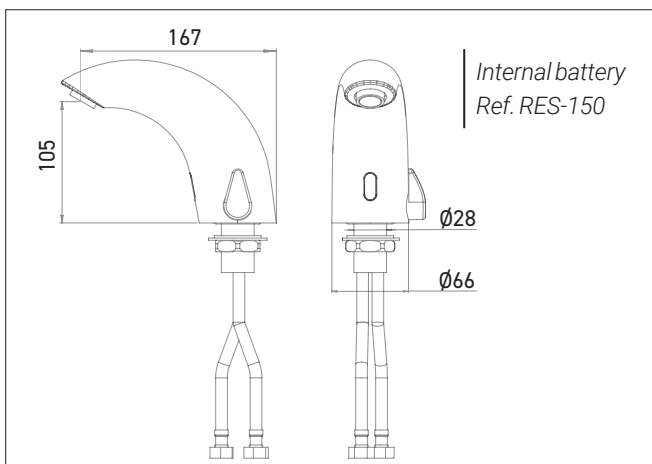

References model choices

SUPREME electronic mixer

- [RES-150](#) **internal battery-powered**
- [RES-152](#) **mains-powered**
- [RES-157](#) **external battery-powered**

Options

- RES-31 Adjustment remote control
- RES-294 IP68 transformer to power up to 4 faucets
- RES-295 Junction box to power up to 10 faucets
- Finishes: Matte black, brushed nickel PVD, matte gold, Antique bronze PVD, copper PVD (contact us)
- Limited flow rate 1.3, 1.9 or 3 L/min
- Vandal-proof aerator
- Second "mixer button" for manual operation