

**ELITE electronic mixer tap**

References: **RES-74 / RES-76**

**Description**

Electronic washbasin mixer faucet with infrared sensor.  
 The vandal-proof brass construction allows for safe installation in high-risk areas.  
 Its elegant design adds a contemporary and polished touch to sanitary spaces.  
 Designed for easy installation and maintenance, with every component seamlessly integrated into the faucet body.  
 Under basin battery access.  
 Electronic faucets reduce water consumption, save energy, and optimize sanitary hygiene.



**Features**

Infrared sensor with optimised presets or adjustable by remote control (flow duration, detection range, temporary stop...).  
 Powered by 9 V alkaline battery or included 230/9V transformer.  
 Low battery indicator light for replacement.  
 Security stop after 90 seconds of uninterrupted use.  
 Periodic hygiene rinse.  
 Chrome-plated brass body.  
 Adjustable NEOPERL aerator to optimise jet direction, with limited flow rate of 6 LPM.  
 On demand, flow limited to 1.3, 1.9 or 3 LPM.  
 SPEX F3/8" hoses (resistant to chlorinated disinfection and temperature increases) with integrated check valves. Filters supplied.  
 Mixes hot and cold water, with the solenoid valve integrated into the faucet body.  
 Water pressure: 0.3 – 8.0 bars. / Maximum temperature 70°C.  
 CE. ACS. 3-year warranty.

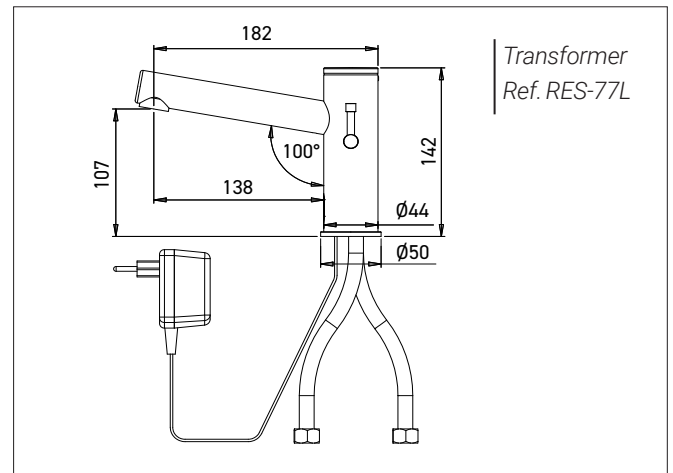
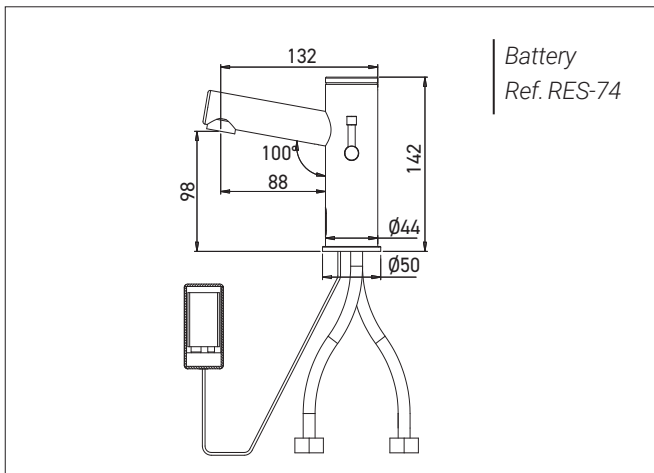

**References** model choices

ELITE Electronic Mixer Faucet

- **RES-74** battery-powered
- **RES-76** mains-powered

**Options**

- RES-31 Remote control
- Finishes Matte Black, Matte White, Matte Gold PVD, Copper PVD, Brushed Nickel PVD
- Brushed stainless steel finish AISI 316 quality
- Limited flow rate 1.3, 1.9 or 3 LPM
- L version with long 138 mm spout
- R version spout 45, 110, 163 or 200 mm raiser
- RES-294 IP68 transformer to power up to 4 faucets
- RES-295 Junction box to power up to 10 faucets
- ...-MH Extended PRM mixer handle